



PHOENIX DEER VALLEY AIRPORT



PHOENIX SKY HARBOR
INTERNATIONAL AIRPORT

America's Friendliest Airport™



PHOENIX GOODYEAR AIRPORT

City of Phoenix Aviation Department Rules & Regulations

Authority: This Rule and Regulation is promulgated pursuant to City Code, Chapter 4 Article I, Sections 4-2, 4-6, 4-12, 4-16, 4-109, 4-116 and Article V, Sections 4-94, 4-95, 4-97, 4-99, 4-100, 4-102, 4-103, 4-104, 4-105, 4-106, 4-107, 4-109, 4-110, 4-116, and 4-117.

Rule and Regulation: **General Aviation Handbook**

This handbook has been developed as an easy reference tool to provide the general aviation tenant with a summary of the Rules and Regulations regarding the use of facilities on City of Phoenix Airports.

The information contained in this publication is not meant to be all-inclusive, but rather to provide answers to commonly asked questions and to supplement the Aviation Department Aircraft Storage Permit.

The **CURRENTLY** adopted City Code, Fire Code, and Construction Code shall be referred to for restrictions, requirements, and enforcement. The Aviation Department may have more stringent requirements than current codes, but cannot be less stringent. Non-compliance with these Rules and Regulations is cause for revocation of a tenant's Aircraft Storage Permit. It is the tenant's responsibility to ensure compliance with these Aviation Department Rules and Regulations by any of their affiliates, guests, subcontractors, or commercial operators.

The final determination regarding the safety, security or compliance of any action will be at the discretion of the City of Phoenix Aviation Department Director of Aviation Services, or designee, the Airport Manager, or designee, for the Phoenix Deer Valley or Phoenix Goodyear Airports (hereafter "Designee"), or the Phoenix Fire Department for all City of Phoenix Airports. Failure to comply with any requirement herein may result in termination of the tenant's Aircraft Storage Permit.



PHOENIX DEER VALLEY AIRPORT



PHOENIX SKY HARBOR
INTERNATIONAL AIRPORT

America's Friendliest Airport™



PHOENIX GOODYEAR AIRPORT

City of Phoenix Aviation Department Rules & Regulations

Sections: I. AIRCRAFT OWNERSHIP

1. Tenant must provide the Aviation Department with the Federal Aviation Administration (FAA) Registry "N" number for the aircraft being stored. Another verifiable country registration will also be accepted.
2. If the aircraft registration is not in the name of the Permittee, then Permittee must provide a copy of a valid lease that provides Permittee exclusive use of the aircraft identified in the Aircraft Storage Permit for at least one year, or the relevant flying club, partnership, or corporation ownership documentation for the aircraft showing the Tenant as a member, co-owner, or officer. "Exclusive" means that no one else, including the aircraft owner, is using the aircraft during the term of lease. The Director of Aviation Services, or designee, has sole and final determination whether the documentation meets this requirement.
3. In the event that a Permittee does not own an aircraft at the time the Aircraft Storage Permit is issued, Permittee shall have ninety (90) days in which to acquire one. Amateur-built aircraft under construction are exempt from this requirement.
4. If the hangar is rented for the purpose of constructing an amateur-built aircraft, or the restoration of any aircraft, then prior to Aircraft Storage Permit issuance, permittee must supply the following for evaluation in accordance with FAA guidelines related to amateur built aircraft:
 - a. Summary statement of the current status of aircraft construction or restoration progress.
 - b. Photographs of major aircraft components and materials already constructed and/or acquired.
 - c. A detailed schedule of construction or restoration with measurable assembly milestones that complies with the maximum allowable timeframe established for aircraft construction and assembly or restoration.
5. Except in exceptional circumstances as determined in the sole discretion of the Director of Aviation Services, a maximum time of seven (7) years from the issuance of the Permit will be allowed for the construction of amateur built aircraft or restoration of an aircraft. Periodic inspections and evaluations will be conducted to ensure that construction/restoration is progressing and meeting the established schedule for completion. Failure to attain a construction/restoration milestone may result in termination of the Aircraft Storage Permit.



PHOENIX DEER VALLEY AIRPORT



PHOENIX SKY HARBOR
INTERNATIONAL AIRPORT

America's Friendliest Airport™



PHOENIX GOODYEAR AIRPORT

City of Phoenix Aviation Department Rules & Regulations

II. HANGAR SPACE

1. Subleasing

- a. Subleasing of aircraft storage space is prohibited.
- b. Temporary storage, up to 90 days, of an aircraft other than the tenant's may be permitted once per calendar year with the written approval of the Director of Aviation Services, or Designee. Any request for temporary storage must be made in writing prior to any actual storage consideration.

2. Required Safety Precautions

- a. The V-shaped opening at the top of interior partitions of Hangars shall not be obstructed.
- b. Fire extinguishers are provided by the City of Phoenix Aviation Department and must remain in the Hangar.
- c. Smoking is strictly prohibited in the Hangar.
- d. "NO SMOKING" signs posted in the Hangar shall be visible and not blocked or obliterated.

3. Hazardous Locations

Certain areas of aircraft Hangars are classified as hazardous locations as depicted in **HAZARDOUS LOCATIONS DIAGRAMS** below.

Hazardous locations are where flammable or ignitable vapor concentrations may exist when the main hangar door is closed causing the hangar space to not be ventilated.

Hazardous locations consist of:

- a. The area located from the floor up to 18 inches above the finished floor throughout the Hangar.
- b. Any area within 5 feet (measured both horizontally and vertically) from aircraft engines and fuel tanks, including down to the finished floor.
- c. Since the locations of fuel tank(s) and engine(s) in the aircraft vary considerably, the Hazardous Locations within an individual hangar are directly dependent upon the configuration of the fuel tank(s) and engine(s) of the specific aircraft stored in the hangar.
- d. Due to the possibility of ignition of flammable or combustible vapors, amenities, such as radios, portable fans, coffee makers, swamp coolers, air compressors, battery chargers and their control equipment, air conditioning units, portable heating units, vacuums, blowers, mobile servicing equipment, etc., and any potential ignition sources are not to be used in the hazardous locations (DIAGRAM A1-A5) where the possibility exists for flammable, ignitable, or combustible vapors and liquids to ignite.



PHOENIX DEER VALLEY AIRPORT



PHOENIX SKY HARBOR
INTERNATIONAL AIRPORT

America's Friendliest Airport™



PHOENIX GOODYEAR AIRPORT

City of Phoenix Aviation Department Rules & Regulations

- e. Electrical equipment approved for use in hazardous locations must be labeled or marked by the manufacturer with "SUITABLE FOR USE IN A CLASS I, DIVISION 2 LOCATION."
- f. Electrical extension cords must be listed and approved (i.e. Underwriters Laboratory (U/L) or Factory Mutual (FM)). **Outlet connectors or extension cords designated for indoor or household use may not be used.** All extension cords/power strips shall be of the heavy-duty type, three wire (two current conductors and a grounding conductor) and **must be disconnected from the power source when the tenant is not in the Hangar.** Daisy chaining extension cords is not permitted.
- g. Electrical extension cords shall only be energized when the tenant is inside the Hangar, shall not be used in place of permanent wiring, and shall be in an undamaged condition with no splicing or electrical tape wrapped around exposed wiring.
- h. Spark producing tools and equipment, such as grinders and electric saws, shall not be used inside the Hangar.
Note: The final determination regarding the safety of any operation, such as cutting, grinding, or drilling may depend on the material being used rather than the tool. For example, aluminum typically will not spark, whereas steel or iron will. Consult the Phoenix Fire Inspector if you are unsure about whether or not a specific tool or piece of equipment can be used inside the Hangar.
- i. Open flames, flame-producing devices and other sources of ignition which include electric space heaters shall not be permitted in the Hangar.
- j. Recognizing that certain types of aircraft engines seep oil under normal conditions, tenants shall locate oil drip pans or buckets under the aircraft engine(s) in order to collect and contain excessive seepage oil. Tenant shall empty and clean drip pans or buckets regularly to ensure that they don't overflow.



PHOENIX DEER VALLEY AIRPORT



PHOENIX SKY HARBOR INTERNATIONAL AIRPORT

America's Friendliest Airport™



PHOENIX GOODYEAR AIRPORT

City of Phoenix Aviation Department Rules & Regulations

Hazardous Locations – Diagram A1

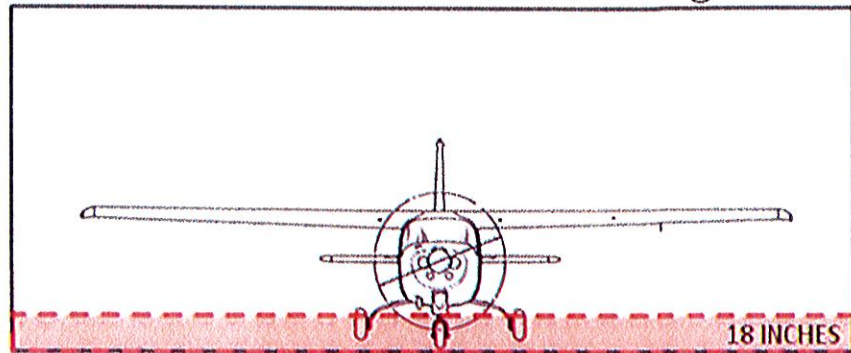

All Aircraft

Hazardous Locations – Diagram A2

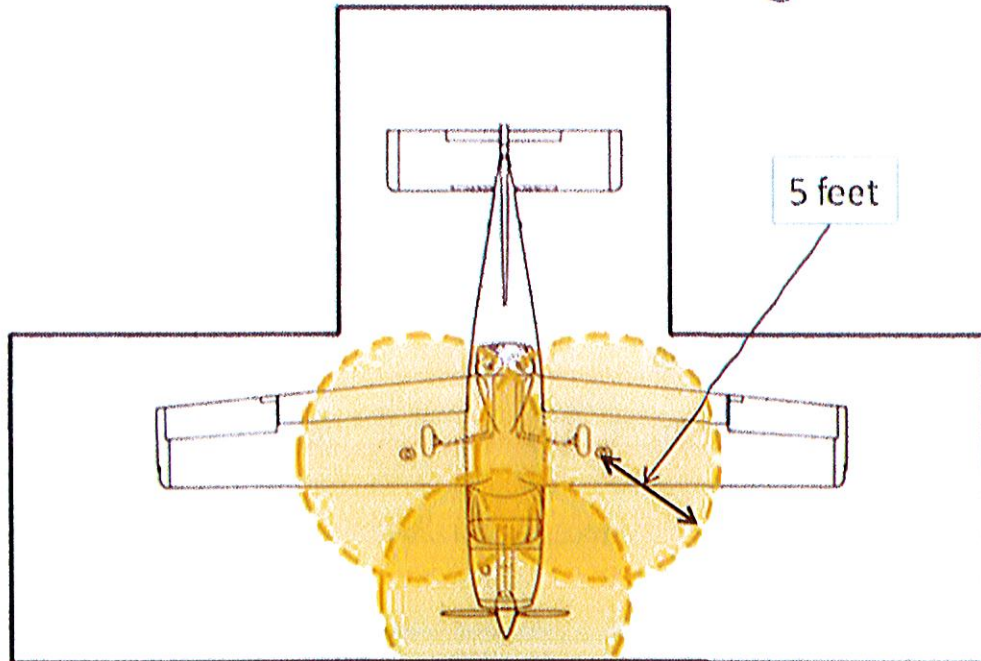

Single Engine

City of Phoenix Aviation Department Rules & Regulations

Hazardous Locations – Diagram A3

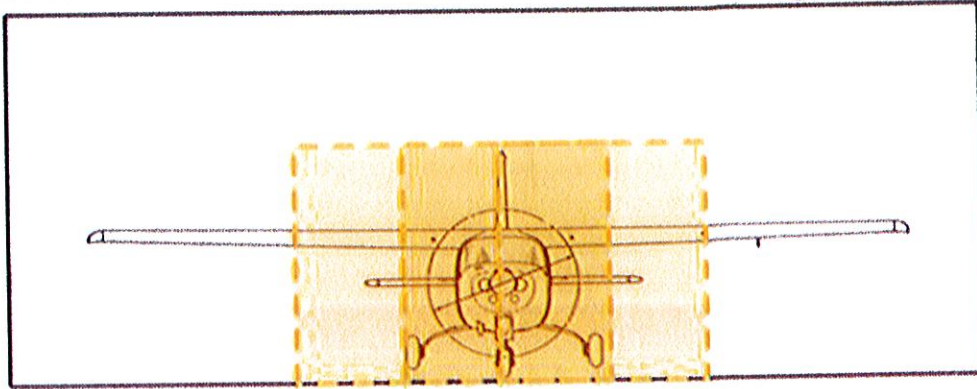

Single Engine

Hazardous Locations – Diagram A4

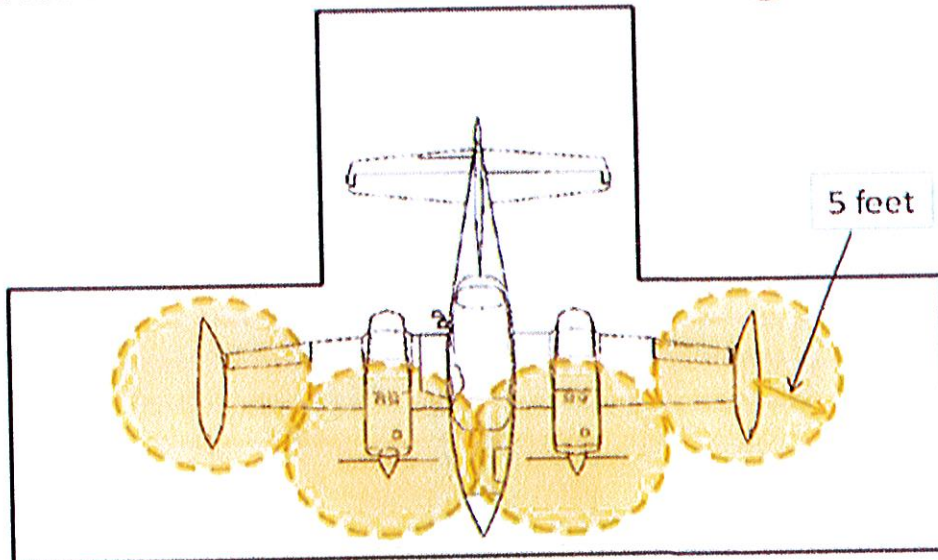

Twin with Tip Tanks



PHOENIX DEER VALLEY AIRPORT



PHOENIX SKY HARBOR
INTERNATIONAL AIRPORT

America's Friendliest Airport™



PHOENIX GOODYEAR AIRPORT

City of Phoenix Aviation Department Rules & Regulations

Hazardous Locations – Diagram A5

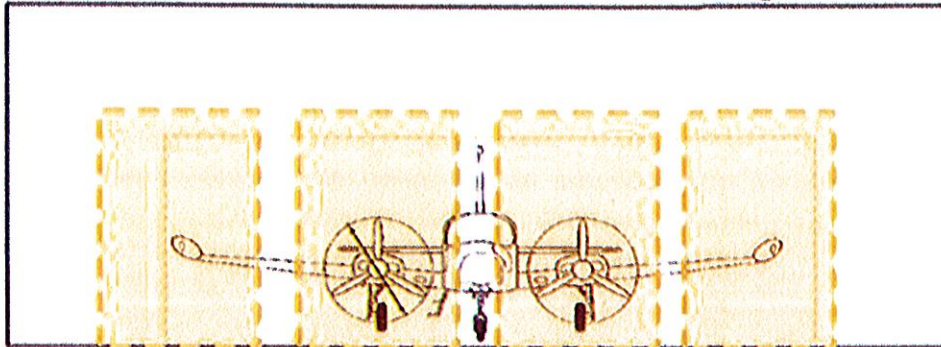

Twin with Tip Tanks

4. Access
 - a. Nothing shall block entry into the Hangar via the pedestrian door.
 - b. Nothing shall be stored in front of the aircraft within the main landing gear track, or higher than the lowest surface of the aircraft wing. Wheel chocks, tow bars, and tugs are permitted in this area.
 - c. Nothing shall be stored within five feet above, below and around the perimeter of the aircraft fuel tank(s) or engine(s).
 - d. Storage in the Hangar must not obstruct fire or emergency access to the rear of the Hangar at any time.
 - e. For aircraft under construction, restoration, or major repair, the perimeter as described in (c), and (d) above, shall be maintained.

III. HANGAR SPACE MAY BE USED FOR:

1. The Hangar is to be used to **store an active and operational aircraft** authorized by tenant's Aircraft Storage Permit. Except for the construction of amateur built aircraft, major restoration or repairs of any aircraft conducted in accordance with the schedule provided by the permittee, all aircraft stored under the permit shall remain in flight-ready condition. To be considered operational, the aircraft shall:
 - a. Have a current FAA registration in accordance with FAR 91.203(a)(2),
and
 - b. Be capable of flight per all FAA requirements.

City of Phoenix Aviation Department Rules & Regulations

Periodic inspections will be conducted to ensure that stored aircraft meet this requirement. Any aircraft found to not be in compliance with this requirement will have ninety (90) days to achieve compliance.

2. The hangar may be used for the construction of amateur built aircraft provided that the tenant complies with the safety requirements and prohibitions in the FAA Hangar Use Policy and this airport rule and regulation. If the aircraft in the hangar is **under construction or restoration**, the activities involved must be no more hazardous than activities involving the installation, removal, or exchange of aircraft parts, i.e., activities do not include any open flames, welding, use of spark producing devices, heating parts, or use of Class I flammable liquids or Class II combustible liquids.

IV. Storage of Items that Comply with the FAA Hangar Use Policy

Tenants may store items in compliance with the Federal Aviation Administration's Hangar Use Policy and Aviation Department Rules and Regulations, as both may be amended.

Storage is subject to the following:

1. Items stored in the hangar shall not impede the movement of the aircraft in and out of the hangar or impede access to the aircraft or other aeronautical contents of the hangar.
2. All stored items must comply with "II. Section 4. Access" above.
3. Aviation items that are directly related to the operation and use of the aircraft can be stored.
 - a. Spare aircraft tires are permitted.
 - b. Two spare aircraft batteries, and a motorized tug battery are acceptable pursuant to NFPA 410 4.2.13 which states "Battery chargers and their control equipment, tables, racks, trays, and wiring shall be located or operated as follows: 1) Not within any of the hazardous areas defined in 513.3 (B) of NFPA 70."
 - i.) **Aircraft batteries shall not be charged while in the aircraft except as allowed under specific rules as approved by the Fire Department.**
 - ii) Battery chargers are permitted provided they comply with NFPA 410-4.2.10 which states mobile chargers shall carry at least one permanently affixed sign to read as follows:

WARNING

Keep (5ft) Horizontally Clear of Aircraft Engines, Fuel Tank Areas, and Vents



PHOENIX DEER VALLEY AIRPORT



PHOENIX SKY HARBOR
INTERNATIONAL AIRPORT

America's Friendliest Airport™



PHOENIX GOODYEAR AIRPORT

City of Phoenix Aviation Department Rules & Regulations

- c. Unattended battery charging is permitted provided that the battery charger is connected directly to the Hangar power supply without an extension cord, and the battery is removed from the aircraft, and the charger and the battery are located outside of the Hazardous Locations in the Hangar.
 - d. Solid state battery maintainers may be continuously energized provided they comply with the previously referenced NFPA code requirements and the Phoenix Deer Valley Airport and Phoenix Goodyear Airport Battery Maintainer Specifications and Procedures document dated August 24, 2017 or later.
 - e. All battery chargers and maintainers must be appropriately FM/UL rated.
4. The amount of combustible/flammable materials (Examples: wood, carpet, rugs, furniture) that can be stored in the hangar is limited to 384 cubic feet, as determined by the Phoenix Fire Department. Because of this, the use of metal shelves, cabinets, work benches, etc., is preferred over wood. Combustible furniture must be limited as follows:
- a. Combustible furniture such as tables, work benches, sofas, chairs, etc., must be limited to 24 (twenty-four) linear feet, combined.
 - b. Prefabricated metal or wooden shelves and cabinets are permitted for storing materials per § V STORAGE PROCEDURE REQUIREMENTS below, and **shall not be attached to the Hangar structure.**
 - i). If used to store flammable/combustible liquids or materials, shelves higher than five feet eleven inches require a permit from the City of Phoenix Planning and Development Department.
 - ii). In hangars with fire sprinklers, shelves greater than four feet by four feet require slatted shelves or sprinklers between the shelves.
5. **Refrigerators** without a manufacturer's label that states "Suitable for Use in a Class I, Division II Location" must be:
- a. Elevated at least 18 inches above the floor,
 - b. Plugged *directly* into the electrical outlet without the use of an extension cord or power strip,
 - c. Must have the original power cord or verification that a longer cord was installed by a licensed professional authorized by the manufacturer to make the modification,
 - d. Located outside hazardous locations (DIAGRAM A).
6. **Vehicles**
- a. Motorized carts or bicycles for use as transportation on the Airport are permitted.

City of Phoenix Aviation Department Rules & Regulations

- b. One aircraft tug, which may be a golf cart, or motorized cart, adapted for aircraft movement which has been approved by the Designee.
 - i). Vehicles used for towing aircraft shall be equipped with a minimum of one listed portable fire extinguisher having a minimum rating of 20-B:C.
 - ii). Walk-behind, hand-operated style tugs are excluded from the fire extinguisher requirements.
 - c. Any vehicle stored in the Hangar with the aircraft, must be outside the Hazardous Location(s) and not impede ingress/egress of the aircraft.
7. **Flammable Liquids/Combustibles**
- a. Classification of flammable/combustible liquids and flash points can be found on a Safety Data Sheet (SDS). The Aviation and Fire Departments have developed storage amounts for flammable and combustible liquids based upon a flash point of 100° F.
 - b. Flammable and combustible liquids must be in their original labeled containers.
 - c. If a tenant (or the inspector) is not sure what class liquid they have, the class will be determined by the associated SDS.
 - d. Tenants may be requested to remove, or have cleaned, any furniture or work surface that appears to be impregnated or soaked with flammable or combustible liquids.
 - e. **Types/examples**
 - i). **Class I Flammable Liquids** have a closed cup flash point at or above 100° F and below 140° F. Acetone, MEK, ethanol, 100LL avgas, turpentine, methyl alcohol, xylene, black wing-walk, gasket adhesive, and most aerosol sprays are examples of Class I Flammable Liquids.
Although the chemical contents of an aerosol spray may have a flash point above 100° F, manufacturers commonly incorporate propane or isobutene as a propellant, which is extremely flammable under pressure. Therefore, if any container utilizes a propellant of this type, it will be counted toward the permissible quantity listed below.
 - ii). **Class II Combustible Liquids** have a closed cup flash point at or above 140° F and below 200° F. Jet A fuel and acetic acid are examples of Class II combustible liquids.
 - iii). **Class III Combustible Liquids** have a closed cup flash point at or above 200° F. Hydraulic fluid, motor oil, lubricating and turbine oils, mineral spirits, and torque seal are examples of Class III combustible liquids.



PHOENIX DEER VALLEY AIRPORT



PHOENIX SKY HARBOR
INTERNATIONAL AIRPORT

America's Friendliest Airport™



PHOENIX GOODYEAR AIRPORT

City of Phoenix Aviation Department Rules & Regulations

f. Permissible Quantities

- i. Class I flammable liquids will be limited to 8 gallons.
- ii. Class II combustible liquids will be limited to 8 gallons.
- iii. Class III A combustible liquids will be limited to 23 gallons.
- iv. Class III B combustible liquids will be limited to 900 gallons.

If a container holding these liquids is empty but has not been made inerted, it will be considered the total quantity of the container.

8. Compressed Gases

- a. Oxygen, nitrogen or any non-flammable compressed gas in a listed, properly identified cylinder or portable tank, must be secured to a fixed location or a portable cart designed for the cylinder(s) or tank(s). Compressed gas cylinders or tanks must have pressure relief devices installed and maintained. Cylinders or tanks not in use shall have a transportation safety cap installed.
- b. Oxygen must be kept a minimum of twenty (20) feet from any flammable or combustible liquid storage.
- c. The maximum permissible quantity of any non-flammable compressed gas is 125 cubic feet.
- d. Storage of flammable compressed gases is not permitted. Examples include, but are not limited to, propane, acetylene.

9. Storage is subject to the following:

- a. No hazardous or dangerous items may be stored in the hangar unless otherwise specifically authorized by this rule and regulation.
- b. All stored items must comply with all CURRENTLY ADOPTED Fire and Building Codes.
- c. Stored materials shall not restrict access to all areas of the hangar to allow for emergency access and response.
- d. Materials shall be stored in an orderly manner and not haphazardly or randomly throughout the Hangar.
- e. Materials shall be stored no higher than twelve (12) feet above the floor, i.e., from the finished floor to the top of the stored materials.
- f. Stored material quantities must not exceed allowed maximum quantities for combustible materials in aircraft storage hangars as defined by local CURRENTLY ADOPTED Fire Code.
- g. Waste products, e.g., wastepaper, wood, or trash, must be removed frequently enough to avoid a risk of fire.



PHOENIX DEER VALLEY AIRPORT



PHOENIX SKY HARBOR
INTERNATIONAL AIRPORT

America's Friendliest Airport™



PHOENIX GOODYEAR AIRPORT

City of Phoenix Aviation Department Rules & Regulations

- h. Materials susceptible to spontaneous ignition, such as oily rags, shall be stored in a listed self-closing disposal container. Contents of such containers shall be removed and disposed of daily.

V. STORAGE PROCEDURE REQUIREMENTS

1. Flammable/combustible liquids

- a. These liquids shall not be stored on the floor and no higher than five feet above the floor (measured from the finished floor to the top of the storage containers).
- b. These liquids shall be stored in an orderly manner in the Hangar.
- c. If a tenant has flammable/combustible liquids in excess of the maximum allowable quantities as identified in "IV. Section 7. f. Flammable Liquids/Combustibles" above, stored in the hangar, the excess amounts shall be stored in metal cabinets that are listed per UL 1275 standard or constructed as follows:
 - i.) **Unlisted metal cabinets**
 - a) Constructed of 18 gauge, or thicker, steel.
 - b) Double-walled with one-and-a-half-inch airspace between the walls, including the doors, floors and tops of the cabinet.
 - c) With riveted or welded joints that are tight-fitting.
 - d) Provided with a conspicuous label in red letters on a contrasting background that reads "FLAMMABLE."
 - e) Provided with well-fitted, self-closing doors equipped with a three-point latch.
 - f) Liquid tight to a height of at least two inches at the bottom.
 - ii.) **Unlisted wooden cabinets**
 - a) Constructed of not less than one-inch nominal thickness exterior grade plywood, including the doors.
 - b) With rabbeted joints and fastened in two directions with wood screws.
 - c) With steel or brass door hinges.
 - d) Painted with intumescent type paint (i.e. paint that is designed to expand in the presence of heat and forms a carbon foam that does not transfer heat easily).
 - e) Provided with a conspicuous label in red letters on a contrasting background that reads "FLAMMABLE."
 - f) Provided with well-fitted, self-closing doors equipped with a three-point latch.



PHOENIX DEER VALLEY AIRPORT



PHOENIX SKY HARBOR
INTERNATIONAL AIRPORT

America's Friendliest Airport™



PHOENIX GOODYEAR AIRPORT

City of Phoenix Aviation Department Rules & Regulations

- g) Liquid-tight to a height of at least two inches at the bottom.
- d. **Aviation fuel** (that is not in the aircraft) shall be stored in containers that are listed by the manufacturer for this use with the listing information on the label.
- 2. All other **hazardous liquids** shall be stored in the manufacturer's original labeled container.
- 3. **Combustible materials**
 - a. Such materials shall be stored no higher than twelve (12) feet as measured from the finished floor to the top of the stored materials.
 - b. Solid combustible materials shall be stored a minimum of four (4) feet away from any flammable/combustible liquids.
- 4. **Non-combustible materials**
 - a. Such materials shall be stored no higher than eight (8) feet as measured from the finished floor to the top of the stored materials.
 - b. Such materials shall be stored in an orderly manner and not haphazardly or randomly throughout the Hangar.

VI. HANGAR ELECTRICAL SYSTEM

- 1. Aircraft hangars are designed and classified for storage or limited servicing of aircraft as described in this Handbook.
- 2. Certain electric hangar doors are equipped with separate "up" and "down" push-button switches. These buttons are designed such that the operator must be present while the door button is activated. Blocking these buttons in either position with any foreign object so that the operator can remove his/her hand from the push-button switch while the door is in motion is prohibited.
- 3. The electrical system serving the Hangar is a 20-amp circuit supplying power to more than one Hangar and was not designed for the additional electrical loads of operating multiple appliances simultaneously. If a circuit breaker does trip, please contact Airport Operations for assistance. **A tenant shall not attempt to reset a tripped circuit breaker.**

VII. BUILDING MODIFICATIONS

- 1. A tenant must receive prior written approval from the Designee before doing **any** modifications or additions to the Hangar, including drilling into the concrete hangar foundation for the purpose of anchor bolt or "eye" bolt installation for work benches or winches. The Designee will advise if a building permit is required. If a building permit is required for



PHOENIX DEER VALLEY AIRPORT



PHOENIX SKY HARBOR
INTERNATIONAL AIRPORT

America's Friendliest Airport™



PHOENIX GOODYEAR AIRPORT

City of Phoenix Aviation Department Rules & Regulations

structural/electrical modifications and is approved by the Designee, the process to obtain a permit is per the following:

- a. The Designee will provide a letter to the tenant which is required to commence the permitting process with the Authorities Having Jurisdiction (AHJ), namely, the City of Phoenix Business and Properties Division of the Aviation Department via the Tenant Improvement (TI) Program, and, for GYR tenants, the City of Goodyear Building Safety Division. Receipt of this approval letter from the Designee **does not relieve tenants** from their responsibility to obtain a building permit that is necessary to receive a "green tag."
- b. The tenant is responsible for providing sufficient information to the AHJ reviewers to approve the scope of work, including but not limited to, providing a drawing of the proposed work and a copy of the approval letter from the Designee.
- c. The tenant is responsible for: adherence to the TI guidelines; all costs associated with the permitting process, required insurance, and modification expenses.
- d. Upon approval to commence work, only a State of Arizona licensed contractor shall perform the work.
- e. Once a permit is issued, the tenant is responsible for coordinating access for the contractor to the Hangar following the "Airside Access and Vehicle Operations Procedures—Phoenix Deer Valley Airport and Phoenix Goodyear Airport" Rules and Regulations.
- f. The tenant is responsible for obtaining inspections by the AHJ and providing the Designee with the "green tag" or certificate of completion from the inspectors which will be maintained in the tenant's Hangar file.
- g. Under no circumstance is a tenant permitted to attach items to the walls of the hangar using new or existing mechanical fasteners.
Drilling holes in the hangar wall is not permissible.
- h. Tenants may hang light-weight decorative items (pictures, clocks, charts, etc.) on the Hangar walls using magnetic hooks or tape.
- i. The tenant is responsible for removing all hangar modifications, at tenant's expense, at the time the Aircraft Storage Permit is cancelled.

VIII. OPEN AND COVERED TIE-DOWNS

1. The prolonged storage of damaged/dismantled aircraft or aircraft that appear not to be operational in open or covered tie-downs or other exposed areas of the Airport shall not exceed thirty (30) calendar days after written notification from the



PHOENIX DEER VALLEY AIRPORT



PHOENIX SKY HARBOR
INTERNATIONAL AIRPORT

America's Friendliest Airport™



PHOENIX GOODYEAR AIRPORT

City of Phoenix Aviation Department Rules & Regulations

- Designee. The tenant is required to correct such conditions with thirty (30) calendar days.
2. Vehicles parked in an open or covered tie-down space while the aircraft is being used shall be parked in a manner so as to be completely contained in the tie-down space and not obstruct adjacent aircraft parking, or taxi lanes, unless for the purpose of immediate and temporary loading, unloading, or staging of an aircraft.
 3. Maintenance in open or covered tie-downs or open is prohibited. (See Section XI below)
 4. Storage of items at open and covered tie-downs is prohibited unless approved by the Designee.
 5. Open and covered tie-downs shall not be used for the purpose of constructing or restoring an aircraft.

IX. MAINTENANCE IN THE HANGAR

1. The only maintenance allowed in a Hangar is the maintenance listed in 14 CFR Part 43 *except* for Appendix A, (b) Major Repairs Item 1 (xxvii) and (c) Preventative Maintenance Items (9) and (10), which are prohibited in Hangars. All work shall be performed within the guidelines established in the FAA Hangar Use Policy.
 - a. Aircraft maintenance work on any aircraft is limited to the exchange of parts and does not include any open flames, welding, use of spark producing devices, heating parts above 500° F, or use of Class I flammable liquids or Class II combustible liquids.
2. **Hazardous activities** such as smoking, fuel service or handling, use of flammable or combustible liquids, painting, paint stripping, doping, welding, production of sparks, or heating parts above 500° F, are prohibited in the Hangar.
3. Limited touch-up painting may be completed in a maintenance bay using aerosol spray cans.

X. Aircraft Maintenance Providers

1. A tenant may choose to use a private company for aircraft maintenance providing the company complies with Phoenix City Code, Chapter 4, and Airport Rules and Regulations. The tenant shall be responsible for all conduct on the Airport by a private company he/she has engaged. The private company must have an approved business permit as set forth in the Minimum Standards to allow them to conduct this commercial activity at the Airport.



PHOENIX DEER VALLEY AIRPORT



PHOENIX SKY HARBOR
INTERNATIONAL AIRPORT

America's Friendliest Airport™



PHOENIX GOODYEAR AIRPORT

City of Phoenix Aviation Department Rules & Regulations

XI. WASH RACKS/MAINTENANCE BAYS

1. **Wash Racks and Maintenance Bays are available on a first come first served basis.**
2. All washing of aircraft is restricted to the designated wash racks.
3. Tenants must not leave the aircraft unattended in the wash rack and must promptly remove the aircraft from the wash rack upon completion of washing and drying the aircraft.
4. Washing of automobiles is prohibited on the airport.
5. Do not wash aircraft parts or do paint stripping with any hazardous products such as Methylene Chloride or Methyl Ethyl Ketone (MEK) in the wash rack or maintenance bay.
6. **Discharging wash water into the City storm water system is strictly prohibited.**
7. **The dumping of any excess fluids such as waste oil, solvents or other cleaning agents into the wash rack drain system is expressly prohibited.**
8. A maintenance bay is available via the "MAINTENANCE BAY SIGN UP SHEET" found in Airport Operations. A lockable storage gang box is available for parts if work is longer than a day, but parts must be secured using an Operations' pad lock.
9. Maintenance bays may be used up to two consecutive days without charge to the tenant. If additional time is required, approval must be obtained from the Designee and appropriate fees may apply.

XII. AIRCRAFT WASHING PROVIDER

1. A tenant may choose to use a private company for aircraft cleaning or washing providing the company complies with Phoenix City Code, Chapter 4, and Airport Rules and Regulations. The tenant shall be responsible for all conduct on the Airport by a private party or commercial operator he/she has engaged and shall ensure compliance with all Aviation Department Rules and Regulations. The private company must have an approved business permit as set forth in the Minimum Standards to allow them to conduct this commercial activity at the Airport and shall abide by all provisions of Section XI.

XIII. ENVIRONMENTAL REQUIREMENTS

1. **STORM WATER POLLUTION PREVENTION PLAN (SWPPP)**
 - a. **All conduct must comply with the Aviation Department SWPPP.**
 - b. **All spills or releases shall be immediately reported to the Airport Operations.**



PHOENIX DEER VALLEY AIRPORT



PHOENIX SKY HARBOR
INTERNATIONAL AIRPORT

America's Friendliest Airport™



PHOENIX GOODYEAR AIRPORT

City of Phoenix Aviation Department Rules & Regulations

- c. Combustible or flammable liquids, including pre-flight fuel samples, antifreeze, or petroleum waste products shall not be discharged or released into storm water drain systems, wastewater (sanitary sewer) systems, or onto the ground or apron.
 - i.) Secondary containment of adequate volume shall be provided for all such liquids.
 - d. Soaps, chemicals, fuels, trash, etc., shall be stored in such a manner that rainfall will not wash residues to the storm water drain system. **Discharges to the storm water drain systems, or onto the ground or apron, may require the responsible party to remediate the discharge to State and/or Federal clean-up standards at his/her own expense.**
 - e. Hangar floors shall be protected from fuel, oil and other spillage through use of drip trays or collection containers.
- 2. AIRCRAFT FUELING**
- a. Aviation fuel shall not be dispensed into or removed from the fuel system of an aircraft within the Hangar.
 - b. **For fueling or defueling operations, the aircraft must be a minimum of fifteen (15) feet outside the Hangar in accordance with NFPA standards. Fifteen (15) feet will be measured from the front of the Hangar to the aircraft fuel filler opening.**
 - c. Fueling and defueling must be done in accordance with the Aviation Department's Fueling Regulations.
- 3. AIRCRAFT FUEL SAMPLES**
- a. Disposal of pre-flight samples on the apron or ground is prohibited. This practice has been deemed unlawful by the Arizona Department of Environmental Quality (ADEQ).
 - i.) Tenants may use fire rated containers in the Hangar (up to five gallons maximum for flammable liquids) for temporary storage prior to disposal.
 - ii.) A fuel/water separator may be used.
Note: The City of Phoenix Aviation Department makes no representation, expressed or implied, regarding the use, safety or availability of this type of product.
 - iii.) If fuel samples cannot be reused, it is recommended that you contact your local fire department, hazardous waste disposal, or recycling centers for proper disposal guidelines. Gasoline is generally an acceptable household hazardous waste at regularly scheduled municipal collection program events.



PHOENIX DEER VALLEY AIRPORT



PHOENIX SKY HARBOR
INTERNATIONAL AIRPORT

America's Friendliest Airport™



PHOENIX GOODYEAR AIRPORT

City of Phoenix Aviation Department Rules & Regulations

4. WASTE SITES

- a. Properly labeled waste disposal drums for used aviation motor oil and solvents are located at each waste site for non-commercial general aviation tenant disposal needs. **Commercial operators are prohibited from using the waste site containers.**
- b. Correctly labeled and caged metal bins are at each waste site for the proper disposal of aircraft tires and aircraft batteries for non-commercial general aviation tenants.

5. DUMPSTERS

- a. Trash dumpsters for non-commercial tenants are located throughout the airport for the disposal of Hangar waste products, e.g., wastepaper, wood, litter, or combustible/flammable waste or rubbish.
Note: Used tires, batteries and hazardous liquids shall not be placed in trash dumpsters. Please contact Airport Operations if you have any questions regarding the disposal of any item.

XIV. Vehicular Parking

1. Parking in Aircraft Storage Space
 - a. Vehicles parked in an aircraft storage space shall be parked in a manner so as to be completely contained in the aircraft storage space and not obstruct adjacent aircraft parking and storage space, or taxilanes unless for the purpose of immediate and temporary loading, unloading, or staging of an aircraft.
 - b. Aircraft parked in an aircraft storage space must comply with the Federal Aviation Administration's Hangar Use Policy, as well as Section III of this handbook.
2. Long/Short Term Parking within the Airport parking areas at DVT
 - a. Short term parking may not exceed three (3) days. Vehicles or trailers parked for more than three (3) days are deemed to be parked long term.
 - b. Long term parking is any parking in excess of three (3) days. In order to park long term, tenants must obtain a parking permit from the Airport. Such permits will only be issued to Airport tenants and only if the vehicle has a clear requirement to be parked at the Airport. Permits for trailers will only be issued to tenants and only for aircraft transport trailers specifically designed to transport the aircraft identified in the tenant's Aircraft Storage Permit. Permit fees may apply. Issuance of any parking permit shall be at the sole discretion of the Director of Aviation Services, or designee.



PHOENIX DEER VALLEY AIRPORT



PHOENIX SKY HARBOR INTERNATIONAL AIRPORT

America's Friendliest Airport™



PHOENIX GOODYEAR AIRPORT

City of Phoenix Aviation Department Rules & Regulations

- c. Recreational vehicles and trailers (other than permitted trailers) may be parked in parking areas, but shall not be allowed to park long term.
- d. Vehicles found in violation of a State law, City Ordinance, or Airport Rules and Regulations, including unregistered or inoperable vehicles, are subject to tow at the owner's expense.

The foregoing R&R is hereby adopted and promulgated this ____ day of _____, 2020.

Charlene Reynolds (Dec 17, 2020 13:49 MST)

Charlene V. Reynolds
Interim Director of Aviation Services

Carolina Potts
Assistant City Attorney IV

